

CB01 SERIES / 3 Directions

Specification

- Pitch : 2.5 mm
- Pin Count : 2 pins in 3 branch direction
- Applied Cable : AWG #20 ~ AWG #28
- Material
 - Terminal : Phosphor Bronze (Tin Plating)
 - Housing : PBT (UL94V-0)
 - Seal : Silicon rubber
- Rated Voltage : AC 250V r.m.s.
- Rated Current : Max. 5A
(When using biggest wire range)
- Withstand Voltage : AC1000V r.m.s. / min.
- Contact Resistance : Under 15MΩ
- Insulation resistance : 1000MΩ
- Temperature Range : -40°C ~ +105°C
(Include temperature rise while energization)
- Waterproof / Dustproof : IP67 (JIS C 0920)

Housing Part Number

■ Type A : (Ins. Dia Φ1.0 ~ Φ1.3)

Female Housing	CB01A6-02*0-01
Male Housing	CB01A5-02*A

■ Type B : (Ins. Dia Φ1.3 ~ Φ1.7)

Female Housing	CB01A6-02*0-02
Male Housing	CB01A5-02*A

- 「*」 stands for Housing Colour. (B . . . Black, N . . . White)
- F Housing . . . Wire Seal and Retainer are already assembled.
- M Housing . . . Wire Seal are already assembled.

Terminal Part Number

■ Small Wire Barrel : Wire Size AWG #22 ~ #28

REC (Female)	CB01C6-010A
----------------	-------------

■ Large Wire Barrel : Wire Size AWG #20 ~ #22

REC (Female)	CB01C6-020A
----------------	-------------

Component

① Retainer	④ REC F-Terminal
② Wire Seal	⑤ Housing Seal
③ F Housing	⑥ M Housing

2.5 mm Pitch 3 way Direction Wire to Wire Waterproof Connector, 2 pins

This waterproof connector was developed to branch in 3 directions by using previous CB01 Series 2 pins, wire to wire , waterproof connector. CB01 Series do not need to crimp Terminals with wire seal. (Wire seal is already installed in the connector) After insertion of crimped Terminals, it can easily get firm waterproofing by pushing the Retainer. Connector Mating lock is applied Latch Lock which enables Low insertion and withdrawal force. CA01 miniturized connector has a hole at the center and can mount with a bolt.

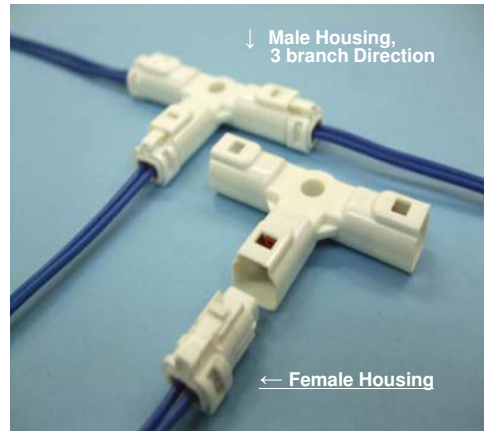

CA01 Series 2 pins in 3 branch direction

Connector Mating figure

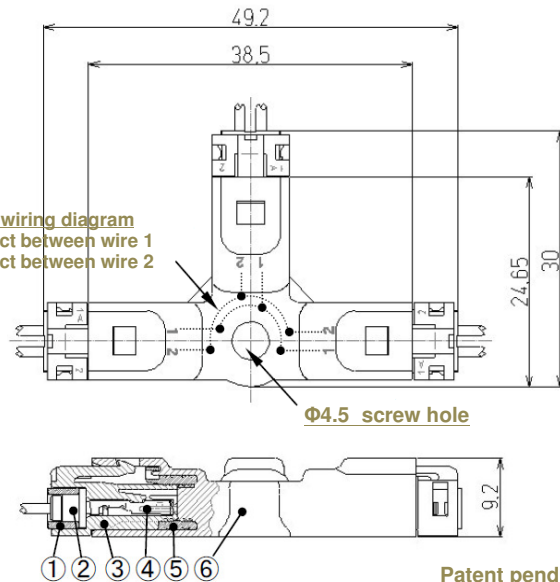

Connector Maker



4-1, Gokanme-cho, Seyaku, Yokohama-city,
 Kanagawa 246-0008
 TEL 81-45-921-2403 FAX 81-45-921-2579

<http://www.sumiko-tec.co.jp>

Official Overseas Agent



金菱有限公司
 GOLDLINK ELECTRONICS LTD.

Unit 8, 16/F., Technology Plaza 29-35
 Sha Tsui Road Tsuen Wa, N.T.
 TEL 852-3119-1098 FAX 852-3119-1009